

METAL EARTH™

3D LASER CUT MODELS

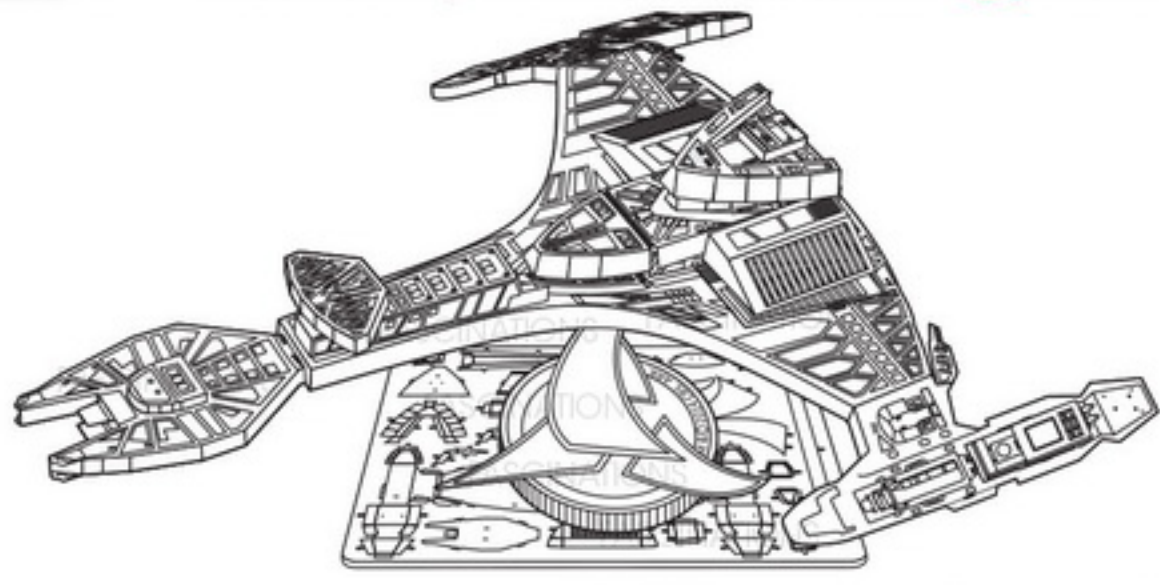

It is highly recommended that you visit www.fascinations.com/metalearth360/mms283 to see the completed model before assembling your own



mms283

To create the best connections

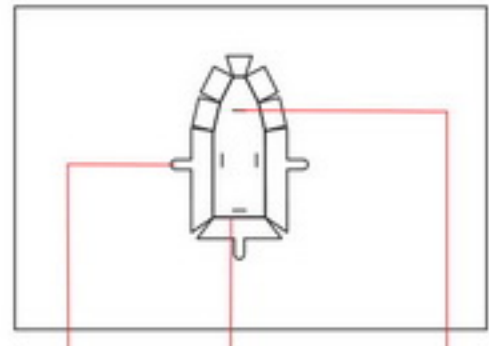

Insertion tabs are inserted and then folded
Fold lines can be seen as shown here

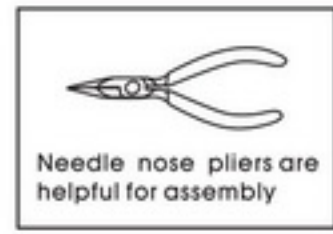

Needle nose pliers are helpful for assembly

● Insert tab and bend 90 degrees for most visible areas

▲ Insert tab and twist 90 degrees is best in some areas to ensure a tight connection

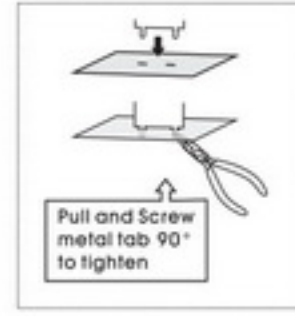

Pull and screw metal tab 90° to tighten

Metal sheets

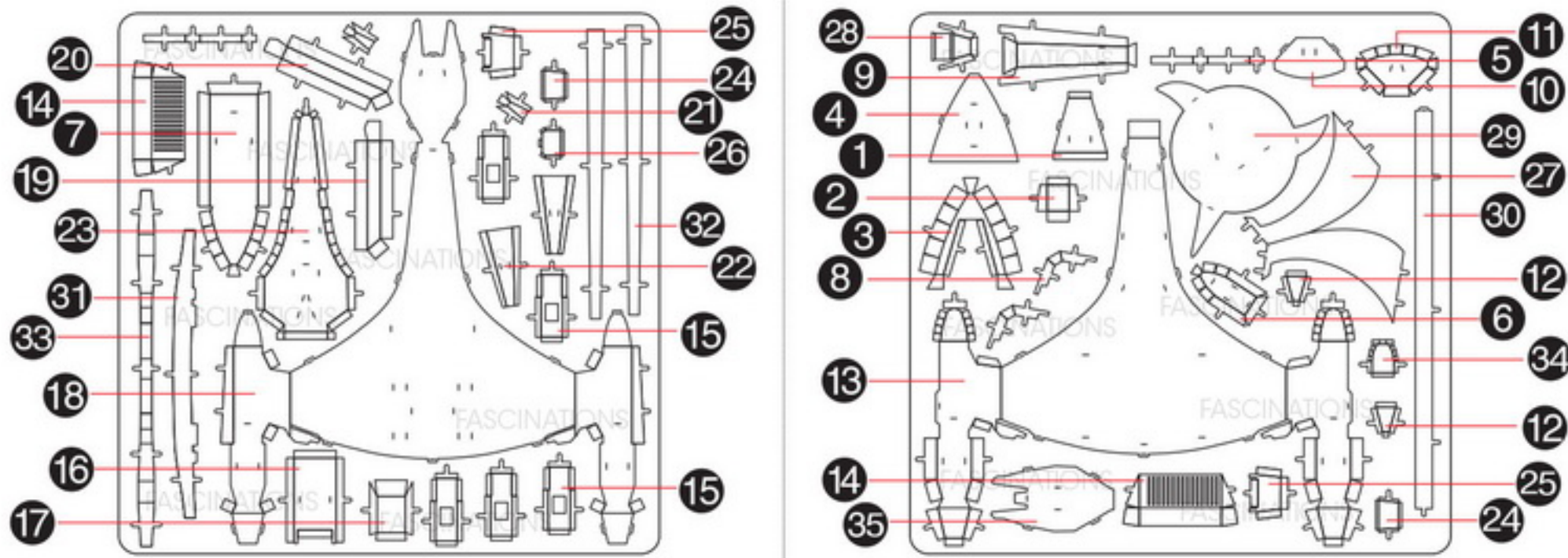

⚠ In order to avoid possible injury from sharp edges, please carefully discard the metal sheet after parts have been removed

Assembly Flow Chart

