

AT-M6 Heavy Assault Walker™
Item No. MMS285



It is highly recommended that you visit www.metal-earth.com/360/mms285 to see the completed model before assembling your own

Legends:

- E** Engraved side
- NE** Non-engraved side
- Attention point
- Insert tab and bend 90 degrees
- Insert tab and twist 90 degrees

Assembly tip:

If needed, slightly twist tabs to hold parts together then untwist and bend them down for a nice finish

Recommended tools:

-Wire cutters: helpful for taking parts from the metal sheets.



-Tweezers or needle nose pliers: helpful for folding parts, bending and twisting tabs.

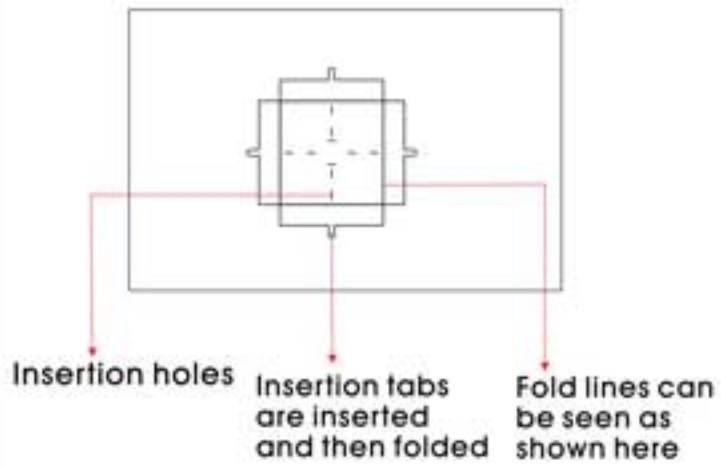
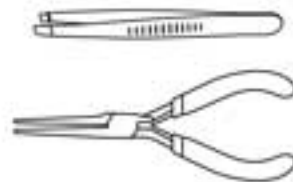

Metal sheet

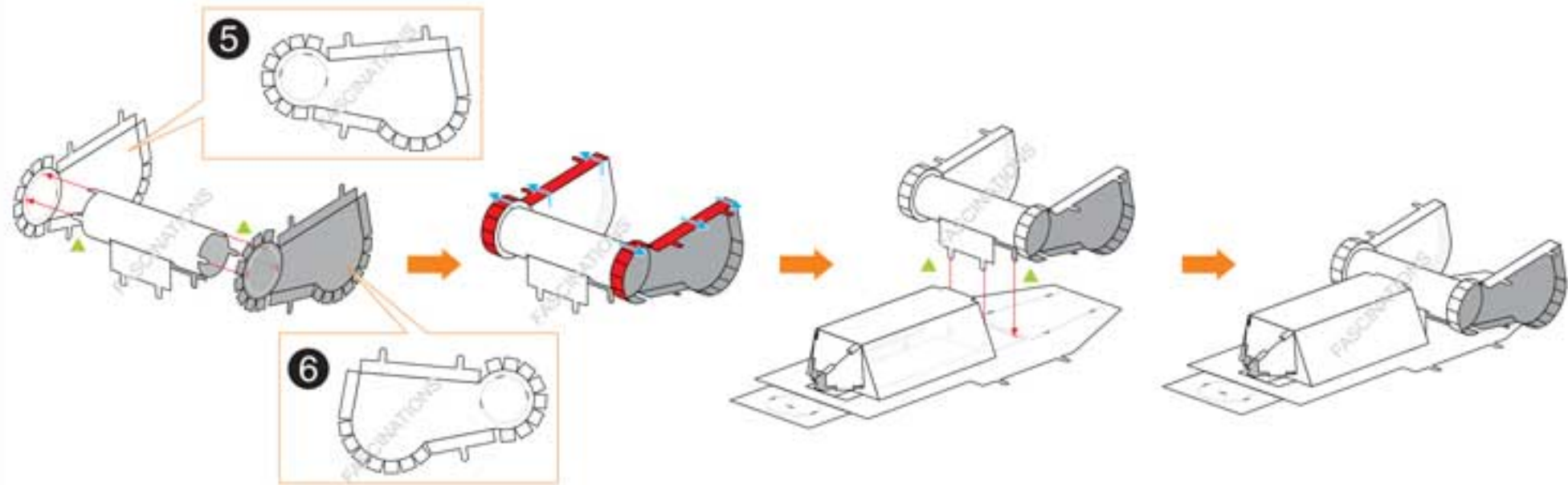
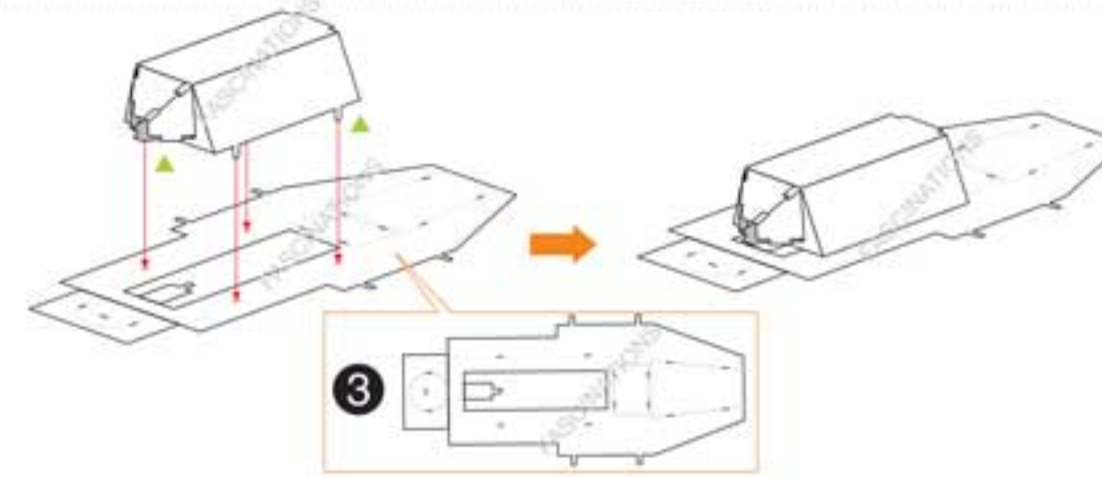
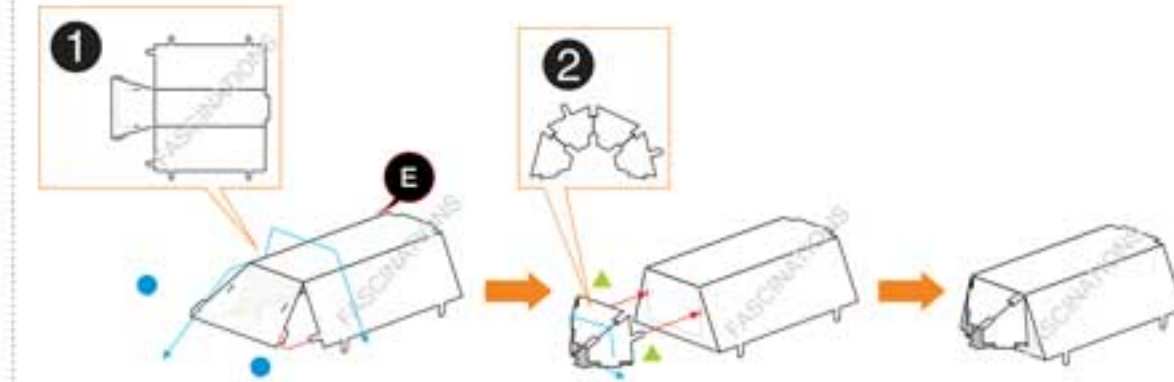
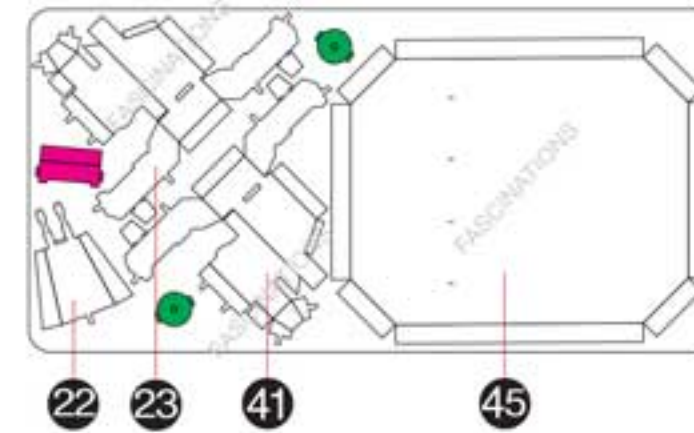

Metal sheets

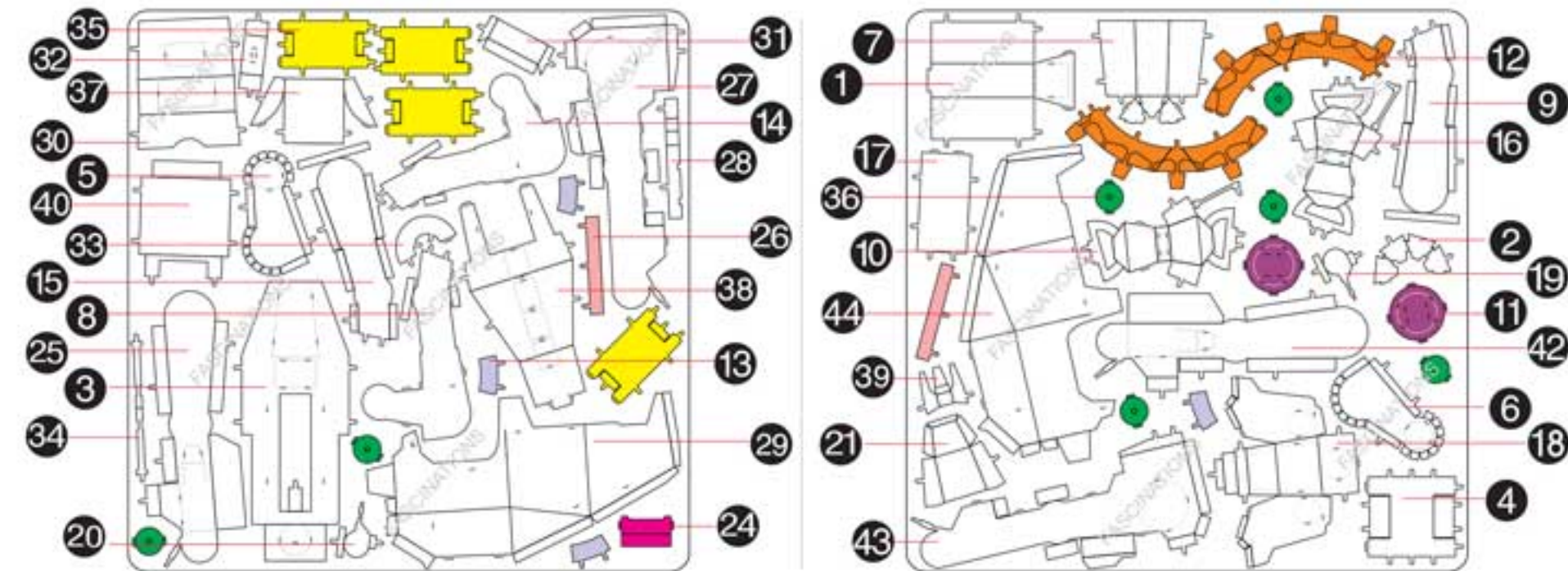

In order to avoid possible injury from sharp edges, please carefully discard the metal sheet after parts have been removed

