

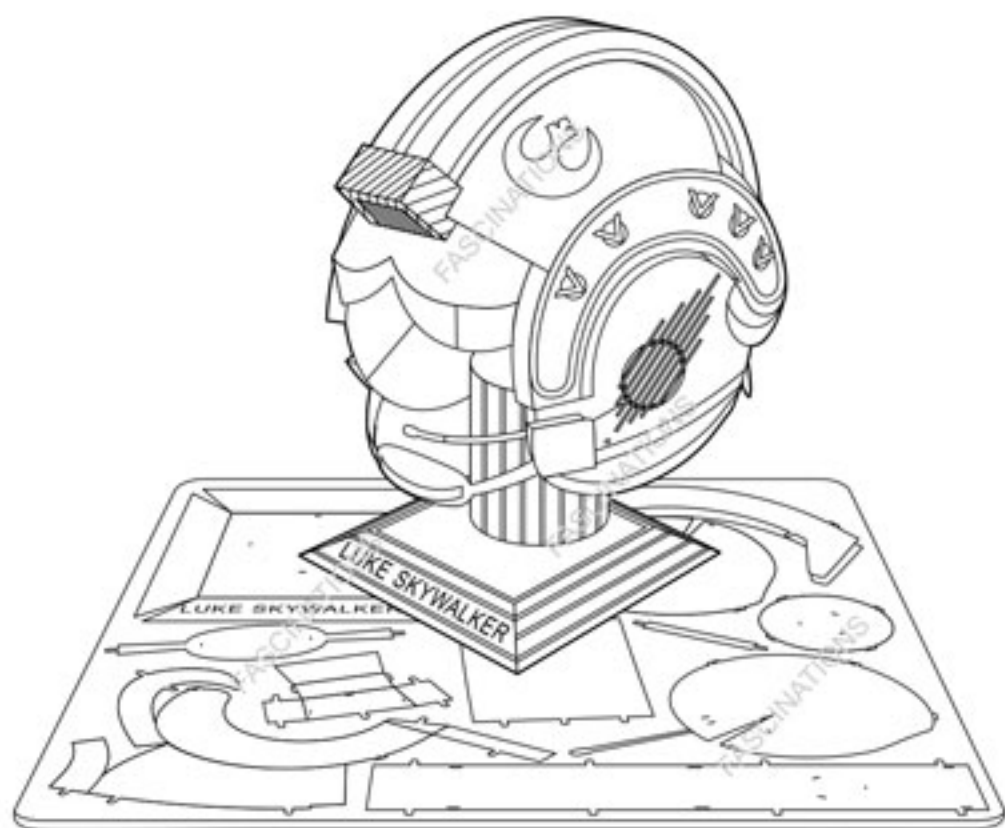

www.starwars.com
© &™ Lucasfilm Ltd.



3D METAL MODEL KITS



Luke Skywalker Helmet™
Item No. MMS318



It is highly recommended that you visit www.metalearth.com/360/mms318 to see the completed model before assembling your own

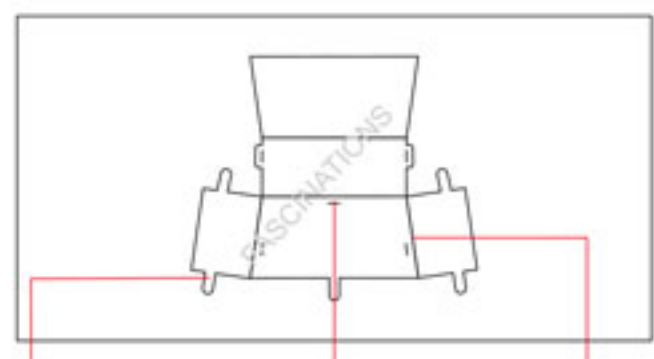

Insertion tabs are inserted and then folded
Insertion holes
Fold lines can be seen as shown here

Legends:

- E** Engraved side
- NE** Non-engraved side
- P** Painted side
- Attention point
- Insert tab and bend 90 degrees
- Insert tab and twist 90 degrees

Assembly tip:

If needed, slightly twist tabs to hold parts together then untwist and bend them down for a nice finish

Recommended tools:

-Wire cutters: helpful for taking parts from the metal sheets.



-Tweezers or needle nose pliers: helpful for folding parts, bending and twisting tabs.

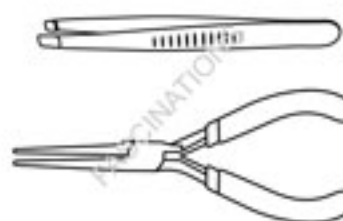

A

Metal sheets

B

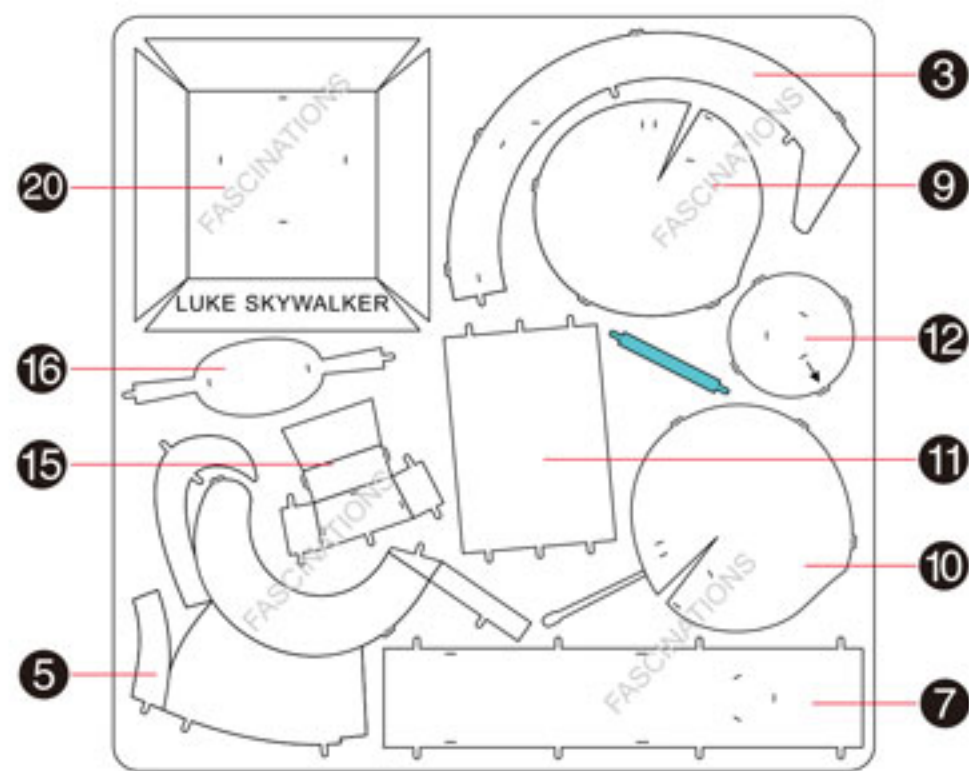
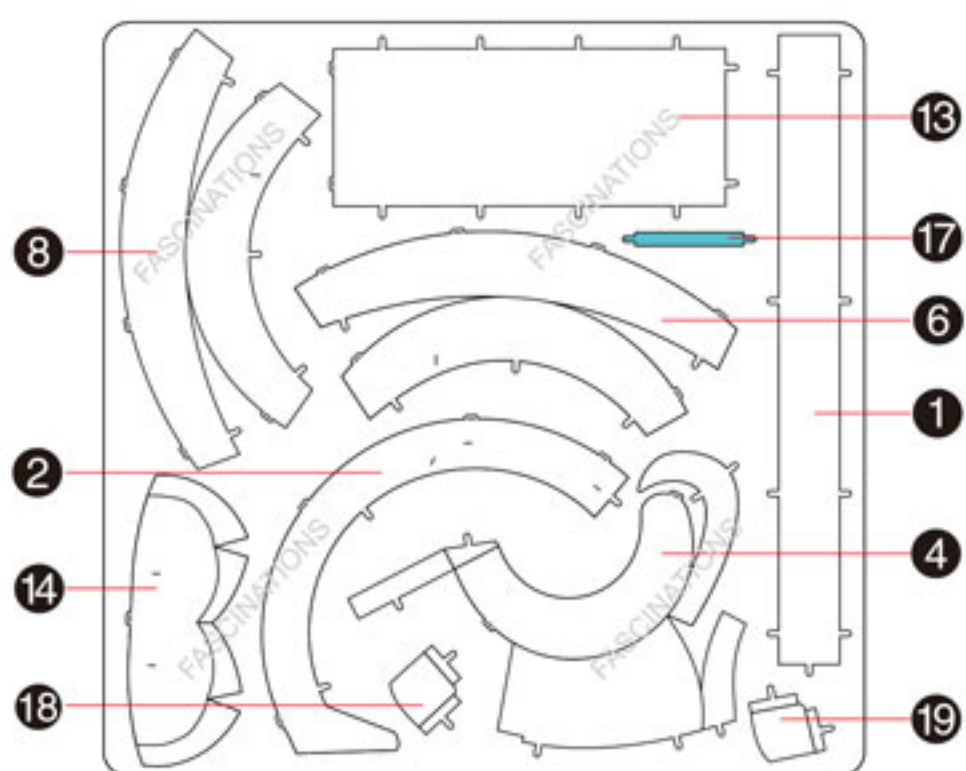

In order to avoid possible injury from sharp edges, please carefully discard the metal sheets after parts have been removed

Assembly Flow Chart

